



Halsey Taylor[®]
Satisfying Thirsts Since 1912

Non-Filtered Bi-Level Wall Mount Water Cooler

MODELS: WM14A-4-BL-Q*

WM16A-3-BL-Q*

Bi-Level Wall Mount Cooler

GENERAL SPECIFICATIONS

Self-contained, electric refrigerated Bi-Level wall-mounted water cooler easily accessible to physically challenged individuals. Models WM14A-4-BL-Q*, and WM16A-3-BL-Q* deliver 13.5-15.5 gph (see chart for actual gph) of 50°F drinking water at 90°F ambient air and 80°F inlet water. Exclusive one-piece, chrome-plated two-stream Double Bubbler™ with non-removable anti-squirt feature and integral hood. Automatic stream height regulator is located inside unit to prevent tampering. Includes self-closing, vandal-resistant pushbutton does not require grasping or twisting. Type 300 series stainless steel cooler top, with satin finish resists stains. Contoured to insure proper drainage. Unit shall be lead-free design which is certified to NSF/ANSI 61 and 372 and meets Federal and State low-lead requirements. The manufacturer shall certify the unit to meet the requirements of NSF/ANSI 61 and 372, UL 399 and CAN/CSA 22.2 No. 120.

STANDARD FEATURES

- Self-closing, vandal-resistant pushbutton does not require grasping or twisting
- Extra deep basin minimizes splashing; with integral drain
- Exclusive one-piece, Chrome-plated two-stream Double Bubbler™ with non-removable anti-squirt feature and integral hood. It's integral hood insures a satisfying drink of water
- Flow regulator provides constant stream from 20 to 105 psi water pressure
- Finish options: Impact-resistant vinyl coating or stainless steel wrapper
- Rated for Indoor use

INLET STRAINER

Easily cleaned in-line strainer screen traps particles of 140 microns or larger before they enter the waterway.

WATER INLET - 3/8" O.D. Tubing. **DRAIN OUTLET** - 1-1/2" tube outlet for 1-1/2" slip joint connection. **Trap and service stop not included.**

COOLING SYSTEM

- Compressor: Hermetically-sealed, reciprocating type, single phase. Sealed-in lifetime lubrication.
- Condenser: Fan cooled, copper tube with aluminum fins. Fan motor is permanently lubricated.
- Cooling Unit: Combination tube-tank type. Self-cleansing. Continuous copper tubing with stainless steel tank. Fully insulated with EPS foam that meets UL requirements for self-extinguishing material
- Refrigerant Control: Refrigerant R134a is controlled by accurately calibrated capillary tube.
- Temperature Control: Easily accessible enclosed adjustable thermostat is factory preset. Requires no adjustment other than for altitude requirements.

Rated for Indoor Use Only



Cooler panels available in Platinum Vinyl or Stainless Steel. (additional cost)

CONSTRUCTION

- Stainless Steel basin with integral drain
- Galvanized structural steel cooler chassis provides structural integrity
- Cooler cabinet available as Platinum Vinyl Clad Steel or Stainless Steel (additional cost)
- Chrome-plated two-stream Double Bubbler™ with non-removable anti-squirt feature and integral hood.

WARRANTY

5 year limited warranty on the unit's refrigeration system. Electrical components and water system are warranted for 12 months from date of installation or 18 months from factory shipment, whichever date falls first.

CAPACITIES CHART									
Model	Order ID	Voltage / Hertz	Chilling** Capacity	F.L. Amps	Rated Watts	Approx. Ship Wt.	UL399 and CAN/CSA 22.2 No. 120 Certified	ADA COMPLIANT	NSF/ANSI 61 and 372 Certified
WM14A-4-BL-Q PV CMPLT	8603140241	115V / 60Hz	13.5 GPH	7.8	690	98 lbs.	•	•	•
WM14A-4-BL-Q SS CMPLT	8603140283	115V / 60Hz	13.5 GPH	7.8	690	98 lbs.	•	•	•
WM16A-3-BL-Q PV CMPLT	7603160241	115V / 60Hz	15.5 GPH	6.5	510	118 lbs.	•	•	•

*Please add the color code of (PV) Platinum Vinyl or (SS) Stainless Steel for the cooler wrapper for your complete sku.

**Based on 80°F inlet water & 90°F ambient air temp for 50°F chilled drinking water.

NOTE: Continued product improvement makes specification sheets subject to change without notice.

Non-Filtered BI-Level Wall Mount Water Cooler ROUGH-IN DIMENSIONS



Halsey Taylor[®]
Satisfying Thirsts Since 1912

Rated for Indoor Use Only

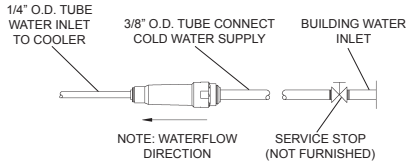

NOTE: A service stop (not included) must be installed at the water inlet line.
NOTE: P-Trap (not supplied) to be installed per local building code.

ELECTRICAL

Furnished with plug-in, 3-wire grounding type service cord. Standard 120 volt, 60 Hz, single phase. Install 120-volt receptacle, rated at 15-amp minimum, to receive 3-wire parallel blade grounding type male plug.

OPERATING PRESSURES

Supply water - 105 psi maximum
Minimum 40 psi supply line pressure required in special circumstances where both sides of bi-level are in use simultaneously to ensure adequate stream height. Use of water filter in this situation is not recommended.

OPERATION OF QUICK CONNECT FITTINGS

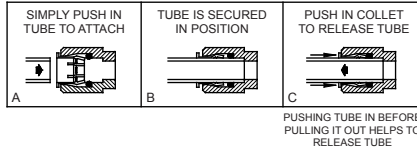

FRONT VIEW

SIDE VIEW

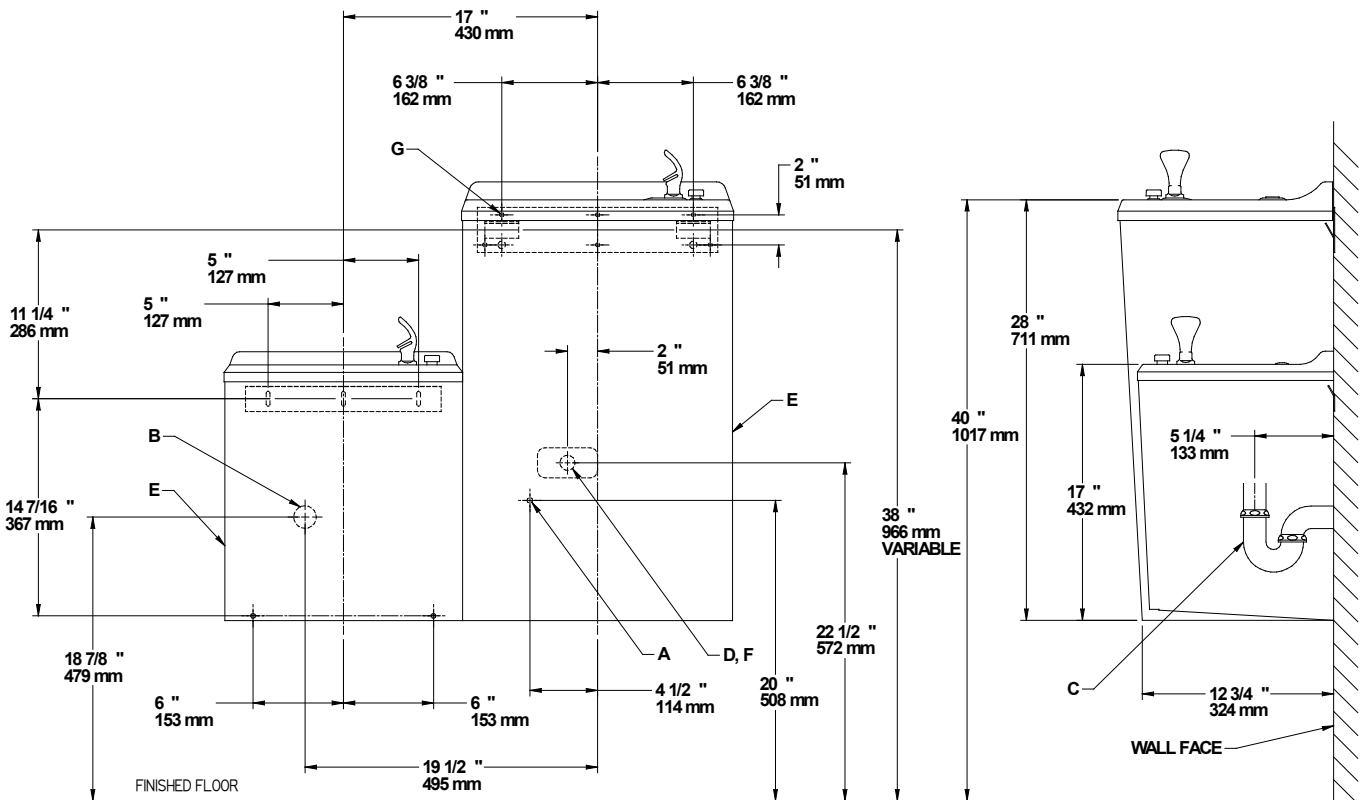

REDUCE HEIGHT BY 3" FOR INSTALLATION OF CHILDREN'S ADA COOLER

LEGEND:

- A = Recommended Water Supply Location. Shut-off valve (not furnished) to accept 3/8" O.D. unplated copper tube. Up to 3" (76mm) maximum out from wall.
 - B = Recommended Waste Outlet location. To accommodate 1-1/2" nominal drain. Drain stub 2" (51mm) out from wall.
 - C = 1-1/2" Trap (not furnished)
 - D = Electrical outlet location
 - E = Insure proper ventilation by maintaining 4" (102mm) minimum clearance from cabinet louvers to wall
 - F = Power cord 4' (1219mm) long
 - G = 1/4" (6mm) screw holes in mounting plate
- **New Installations Must Use Ground Fault Circuit Interrupter (GFCI).

Job Name: _____

Model: _____ Qty. _____

Contact: _____

Approval Signature: _____

Notes: _____

Halsey Taylor[®]